

DR. BABASAHEB AMBEDKAR TECHNOLOGICAL UNIVERSITY, LONERE

Regular End Semester Examination – Summer 2022

Course: B. Tech.

Branch : First Year

Semester : II

Subject Code & Name: BTES205E Energy and Environment Engineering

Max Marks: 60

Date: 29/08/2022

Duration: 3.45 Hr.

Instructions to the Students:

1. All the questions are compulsory.
2. Each question carries 12 marks.
3. Illustrate your answers with neat sketches, diagram etc., wherever necessary
4. The level of question/expected answer as per OBE or the Course Outcome (CO) on which the question is based is mentioned in ( ) in front of the question.
5. Use of non-programmable scientific calculators is allowed.
6. Assume suitable data wherever necessary and mention it clearly.

	(Level/CO)	Marks
<b>Q. 1 Solve Any Two of the following.</b>		
A) Write the sequence of energy transformations taking place in the following: Nuclear power plant, Gas turbine and Hydro Power plant	BTES205-1/2	6
B) Explain the function of following components used in power plant: i) Condenser ii) Nuclear Fuel. iii) Penstock.	BTES 205-3	6
C) What is a nuclear chain reaction? Explain the importance of moderator and control rods in a nuclear reactor with respect to chain reaction?	BTES 205-1/3	6
<b>Q.2 Solve Any Two of the following.</b>		
A) What is the source of tidal energy? What are the potential sites of tidal energy in India?	BTES 205-2/3	6
B) What is Bio-mass? Write the percentage composition of Bio-gas. What are the environmental and health benefits of Bio-gas utilization?	BTES 205-2	6
C) How the Wind mills are classified? Sketch the diagram of a HAWT, and explain the function of its main components.	BTES 205-2	6
<b>Q. 3 Solve the following.</b>		
A) What do you understand by maximum energy efficiency in context with energy conservation principle? Discuss with a suitable example.	BTES 205-1	6
B) How do you conserve the energy in pharmaceutical industry? Write the suitable measures.	BTES 205-1	6
<b>Q.4 Solve Any Two of the following.</b>		
A) What are the fixed major sources of outdoor pollution? What effects does air pollution have on Health of animals and plants and materials.	BTES 205-1	6
B) Differentiate between	BTES 205-4	6

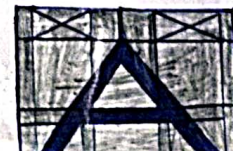



- A i) Dust and smoke.
- ii) Pollutants and Toxicant.
- iii) Smoke and Smog.

A Q Explain the types of water pollutants in brief. How do vehicles responsible for water pollution? BTES 205-4 6

**Q. 5 Solve Any Four of the following.**

- A) H What are the effects of noise pollution on children's health? BTES 205-4 3
- A B) What is marble cancer? How is Taj Mahal turning yellow? BTES 205-4 3
- C) Write in brief about the sources of thermal pollution and its effects. BTES 205-4 3
- A D) How oil spills and sediments degrade the water quality? Explain. BTES 205-4 3
- A E) Write briefly about the major sources of noise pollution. BTES 205-4 3
- F) H What is radioactive pollution? What are its effects? BTES 205-4 3

\*\*\* End \*\*\*

Enggsolution



**DR. BABASAHEB AMBEDKAR TECHNOLOGICAL UNIVERSITY, LONERE**

Regular End Semester Examination – Summer 2022

Course: B. Tech. (First Year All Branches Group B)

Semester: II

Subject Code & Name: BTES203G Engineering Graphics

Max Marks: 60

Date: 23/08/2022

Duration: 5 Hrs.

**Instructions to the Students:**

1. All the questions are compulsory.
2. The level of question/expected answer as per OBE or the Course Outcome (CO) on which the question is based is mentioned in ( ) in front of the question.
3. Use of non-programmable scientific calculators is allowed.
4. Assume suitable data wherever necessary and mention it clearly.

(Level/CO) Marks

**Q. 1** Solve the following.

- A) Construct a regular pentagon of 30 mm side by general method.  
 B) Explain the different methods of dimensioning.

Remember 06  
 Understand 06

**Q.2** Solve Any one of the following.

- A) Draw the elevation, top view and side view of the object shown in figure 1.  
 All dimensions are in mm.

Apply 12

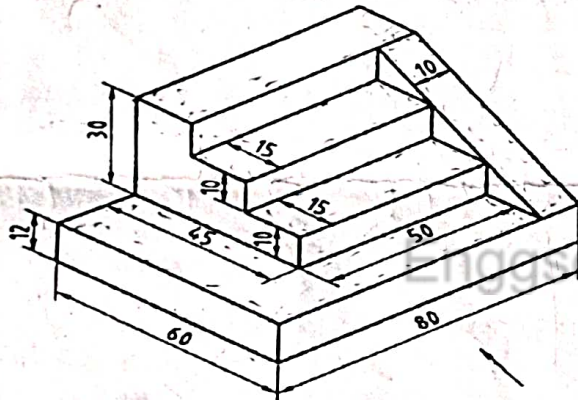

Figure: 1

- B) Draw the elevation, top view and side view of the object shown in figure 2. All dimensions are in mm.

Apply 12

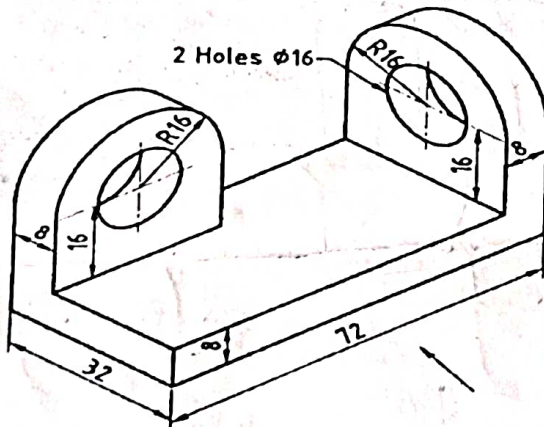
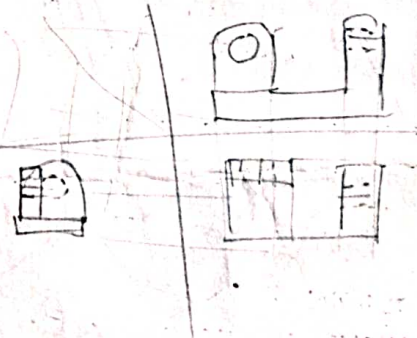

Figure: 2



**Q. 3** Solve Any Two of the following.

- A) Line AB is 75 mm long. It's F.V. and T.V. measure 50 mm & 60 mm long respectively. End A is 10 mm above H.P. and 15 mm in front of V.P. Draw projections of line AB if end B is in first quadrant. Find angle with HP and VP.  
 B) End A of a line AB is 25 mm below HP and 35 mm behind VP. Line is 30° inclined to HP. There is a point P on AB contained by both HP & VP. Draw projections; find inclination with VP and traces.

Evaluate 06

Evaluate 06



C) A hexagonal plane has its one side in HP and its opposite parallel side is 25 mm above HP and in VP. Draw its projections. Take side of hexagon 30 mm long. Evaluate 06

Q.4 Solve Any Two of the following.

A) A right circular cone, 40 mm base diameter and 60 mm long axis is resting on HP on one point of base circle such that its axis makes  $45^\circ$  inclination with HP and  $40^\circ$  inclination with VP. Draw its projections. Evaluate 06

B) A frustum of regular hexagonal pyramid is standing on its larger base. On HP with one base side perpendicular to VP. Draw its FV & TV. Project its auxiliary TV on an AIP parallel to one of the slant edges showing TL. Base side is 50 mm long, top side is 30 mm long and 50 mm is height of frustum. Evaluate 06

C) A cylinder 40 mm diameter and 50 mm axis is resting on one point of a base circle on VP while its axis makes  $45^\circ$  with VP and FV of the axis  $35^\circ$  with HP. Draw projections.. Evaluate 06

Q.5 Solve the following.

F.V. and S.V. of an object are given. Draw its isometric view.

Synthesize 12

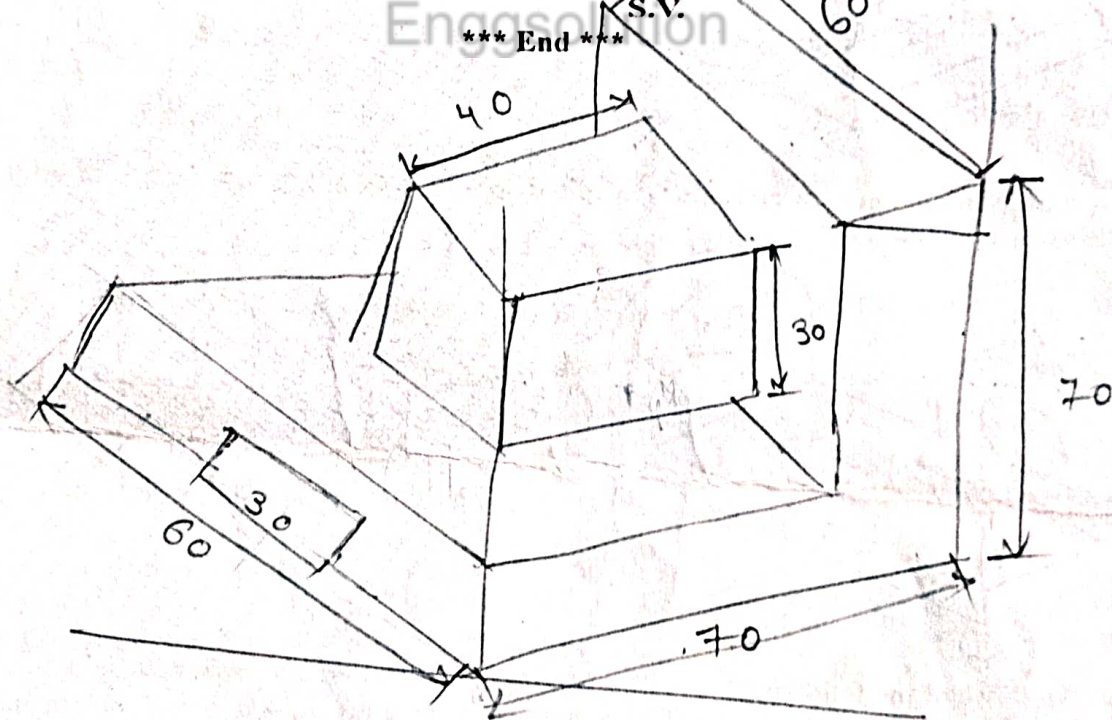
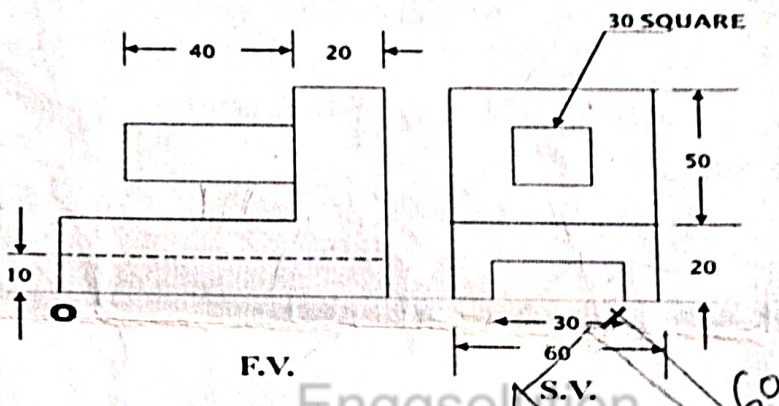



**DR. BABASAHEB AMBEDKAR TECHNOLOGICAL UNIVERSITY, LONERE**

Regular End Semester Examination – Summer 2022

Course: B. Tech.

Branch: All branches (Group B)

Semester: II

Subject Code & Name: BTBSP202 Engineering Physics

Max Marks: 60

Date: 20/08/2022

Duration: 3.45 Hr.

**Instructions to the Students:**

1. All the questions are compulsory.
2. The level of question expected answer as per OBE or the Course Outcome (CO) on which the question is based is mentioned in ( ) in front of the question.
3. Use of non-programmable scientific calculators is allowed.
4. Assume suitable data wherever necessary and mention it clearly.

	(Level/CO)	Marks
<b>Q. 1 Solve Any Two of the following.</b>		
A) In case of Forced vibrations, prove that	(CO1) (Understand)	6
$A = \frac{f}{\sqrt{(\omega^2 - p^2)^2 + 4b^2p^2}}$		
B) Explain the construction and working for production of ultrasonic waves using Piezoelectric Oscillator.	(CO1) (Understand)	6
C) Write any two applications of ultrasonic waves. Calculate the thickness of quartz plate which is used to produce ultrasonic waves of 2 MHz. Density of quartz is $2.65 \times 10^3 \text{ kg/m}^3$ and Young's modulus is $8 \times 10^{10} \text{ N/m}^2$	(CO1) (Remember & Understand)	6
<b>Q.2 Solve Any Two of the following.</b>		
A) Derive an expression for diameter of Newton's bright and dark rings.	(CO2) (Understand)	6
B) Explain the construction and working of Ruby Laser.	(CO2) (Understand)	6
C) State and explain Brewster's law.	(CO2) (Remember & Understand)	6
With a slab of flint glass, the angle of polarization is found to be $62^\circ 24'$ . Calculate the refractive index of the flint glass.		
<b>Q. 3 Solve Any Two of the following.</b>		
A) With neat diagram, explain the construction and working of Bainbridge Mass Spectrograph.	(CO3) (Understand)	6
B) Explain the construction and working of Geiger Muller Counter.	(CO3) (Understand)	6
C) Derive Schrodinger's time independent wave equation.	(CO3) (Understand)	6
<b>Q.4 Solve the following questions.</b>		
A) Calculate atomic radii in SC, BCC and FCC lattices with suitable diagrams.	(CO4) (Understand)	6
B) Explain characteristics and continuous X-ray spectra.	(CO4) (Understand)	6
<b>Q. 5 Solve Any Two of the following.</b>		
A) Explain B-H curve for ferromagnetic materials. Define the terms Coercivity and Retentivity.	(Understand)	6
B) Distinguish between Type I and Type II superconductors.	(Understand)	6
C) What is Hall effect? Derive an expression for Hall Voltage and Hall Coefficient.	(Understand) (Remember & Understand)	6

\*\*\* End \*\*\*